

# RAIN/MAINS CHANGEOVER SYSTEMS

## MaxiSAVE 20mm Rain/Mains Systems

### MHR20 SERIES

## MHR20-370/550



### APPLICATION

- The MHR20 Series is a fully Automatic Hydraulic Rain / Mains water changeover device designed for pressure pump supply systems in harvesting rainwater for the toilet, laundry and household applications with automatic mains backup.
- The MHR20 Valve is designed to operate with an electronic pressure controller with auto restart not requiring a float switch. This design makes the MHR20 System very simple to install.
- The MHR20 Valve comes with 3/4" outlet, which makes the system ideal for domestic applications. Certified to: WaterMark ATS 5200.477 WMK 60075 Complies with AS/NZS 3500.1 when installed by a licensed plumber.

Note: Should the static mains supply be greater than 400 kPa above the supply pressure of the pump the device will not completely isolate mains water.

### VALVE SPECIFICATIONS

- Max mains pressure 500 KPa
- Max pump pressure 600 KPa
- Flow rate >50 LPM
- Max Water Temperature 40C
- Rainwater Inlet 25mm 1" BSP F
- Mains Water in 20mm 3/4" BSP F
- Outlets 20mm 3/4" BSP F

### CONSTRUCTION

- Pump body: AISI 304 Stainless steel
- Impeller: Stainless steel
- Motor Shaft: Stainless steel
- Mech seal: Ceramic / Graphite / NBR

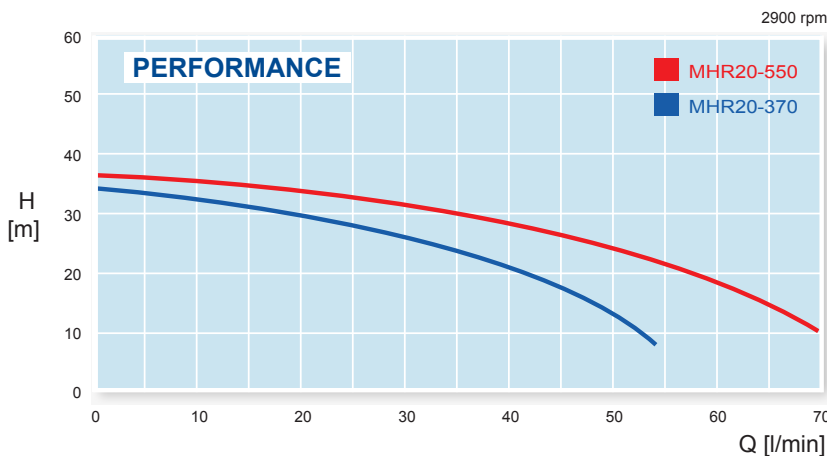

### Installation Guide

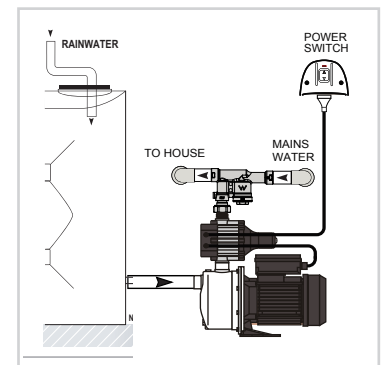

### TECHNICAL DATA

Model	Description	Power (kW)	Head (m)	Flow (L/min)	Outlets	Applications
MHR20-370	HYJET Hydraulic Rain/Mains System with HSJ370 Pressure Pump	0.37	36	55	3	Double Storey
MHR20-550	HYJET Hydraulic Rain/Mains System with HSJ550 Pressure Pump	0.55	38	70	4	Double Storey